

ABSTRACT

This paper presents Fuzzy logic based control of matrix converters for AC drives. Matrix Converters can directly convert ac power supply of fixed voltage into ac voltage of variable amplitude and frequency. Matrix Converter is a single stage converter. The matrix converters can contribute to the realization of low volume, sinusoidal input current, bidirectional power flow and lack of bulky reactive elements. All these reasons lead to the development of matrix converter. Based on the control techniques used in the matrix converter, the performance varies. In this paper the performance of matrix converter with PWM modulation technique with using FLC and without using FLC is analyzed. The basic principle and switching sequence of this modulation technique is also presented in this paper. The output voltage, output current waveforms and THD spectrum of switching waveforms connected to RL load are analyzed by using Matlab/Simulink software. The simulated results show that the THD is better for PWM technique using FLC

KEYWORDS: Matrix Converter, Pulse Width Modulation (PWM), Fuzzy Logic Controller (FLC), Total Harmonic Distortion (THD).

INTRODUCTION

As demand for energy savings has increased in recent years, inverters are being used in a wider range of applications. Demand for low cost, smaller size and higher efficiency will continue to further expand the range of inverter applications. However, as a trend towards eco-friendly products increases, some sort of measure is necessary to suppress the harmonics present in the inverter input current. In power electronic applications direct AC/AC conversion plays an important role. This direct AC/AC conversion provides inherent attractive characteristics. The need to increase the quality and the efficiency of the power supply and the power usage, the three phase matrix converters become a modern energy converter and have emerged from the early conventional energy conversion modules. The matrix converter is an alternative to an inverter drive for a frequency control. The matrix converter is also known as an 'all-silicon solution'. The matrix converter is a single stage converter which does not require any capacitor as the dc-link energy storage component. The capacitor can be a critical component because it is large and expensive. In addition, the matrix converter has a high power factor sinusoidal input current with a bi-directional power flow for the whole matrix converter drive system. It has a longer life because no capacitor is used. It has many advantages over a rectifier fed inverter system. Different switching schemes for an ac/ac matrix converter have been proposed to achieve sinusoidal input and output current waveforms. Several publications on matrix converters have dealt with the modulation strategies to improve the performance of the matrix converter [1].

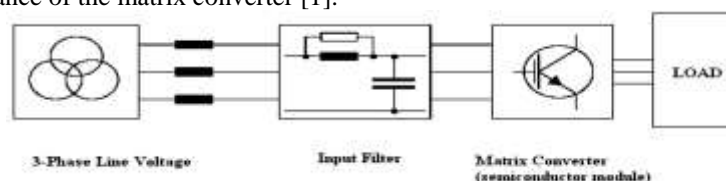

Fig.1: Block-Diagram for the Matrix Converter fed Load

PULSE WIDTH MODULATION TECHNIQUE

Because of advances in solid state power devices PWM based converters are most widely used in drives. PWM inverters makes it possible to control both the frequency and magnitude of the voltage and current applied to drive the motor. The energy that a PWM converter delivers to a motor is controlled by PWM signals applied to the gates of the power switches. Different PWM techniques exist, that are Sinusoidal PWM, Hysteresis PWM and the relatively new Space-Vector PWM. These techniques are commonly used for the control of ac induction, Brushless Direct Current (BLDC) and Switched Reluctance (SR) motors. As a result, PWM converter powered motor drives offer better efficiency and higher performance compared to fixed frequency motor drives.

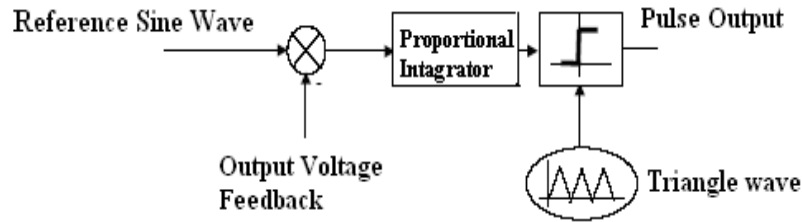

Fig.2: PWM Pulse Generation Circuit

The generation of PWM pulse requires reference sine wave and triangular wave. The reference sine wave is compared with the feedback from the output voltage is amplified and integrated as shown in figure 2. This signal is then compared with a generated triangular wave. The rectangular wave is the result of this comparison.

FUZZY LOGIC CONTROLLER

Fuzzy logic becomes more popular due to dealing with problems that have uncertainty, vagueness, parameter variation and especially where system model is complex or not accurately defined in mathematical terms for the designed control action. The conception of the fuzzy logic introduced by Zadeh [6] is a combination of fuzzy set theory and fuzzy inference system (FIS). Elements of a fuzzy set belong to it with a certain degree, called degree of membership. The degree of membership is a result of mapping the input to certain rules using a membership function (MF). The progression which maps the specified input data to the output using fuzzy logic is known as fuzzy inference. The output of FLC is considered as pulses for triggering IGBTs. In this paper seven triangular membership functions have been chosen for representing numerical variables into linguistic variables [6], viz., NL (negative large), NM (negative medium), NS (negative small), ZE (zero), PS (positive small), PM (positive medium), PL (positive large). The spacing between MFs may be equal or unequal; it is set here for cover a band of load current with good accuracy. After this rules formation as knowledge base, different inference mechanisms have been developed for defuzzify fuzzy rules. In this paper, authors apply Mamdani's max-min inference method to get an implied fuzzy set of tuning rules. Finally center of mass method is used defuzzify the implied control variables.

MODELING OF MATRIX CONVERTER

Implementation of the matrix converter is done using Matlab / Simulink tools. The different modulation techniques are used to provide the pulses for the matrix converter. The converter consists of nine modular H-bridge capacitor clamped switch cells, as illustrated in figure 3 connected from each input phase to output phase.

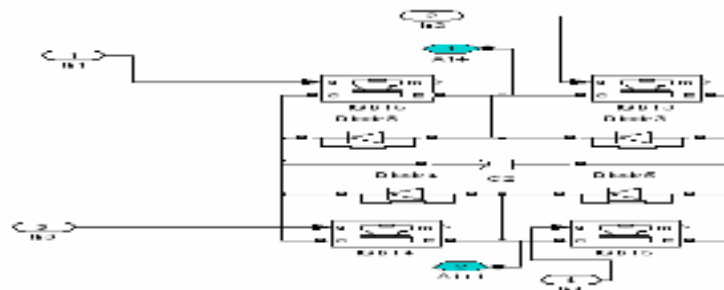

Fig.3: H-Bridge Switch Cell with Capacitor

The ac supply is given to the H- bridge switch cell through the filter circuit. Each switch cell consists of four IGBTs and one capacitor. The gate pluses for the switches are given through the PWM pulse circuits.

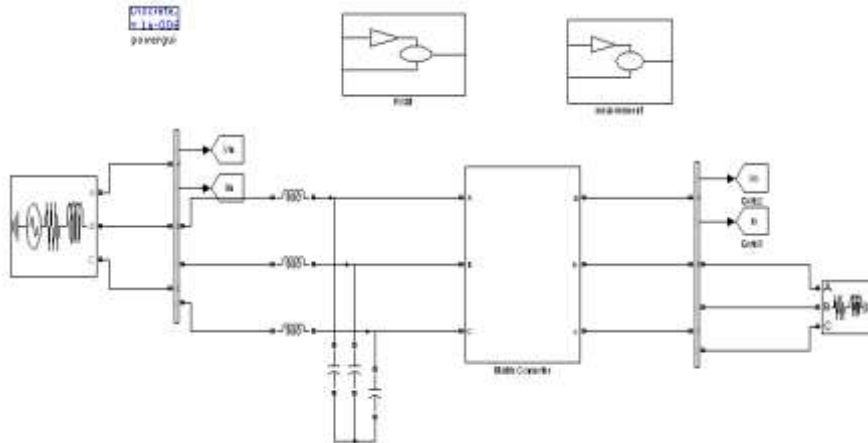

Fig.4: Matlab/Simulink Blocks for Matrix Converter Employing PWM Technique

Figures 4-5 represents the matrix converter unit with PWM modulation technique with and without FLC respectively.

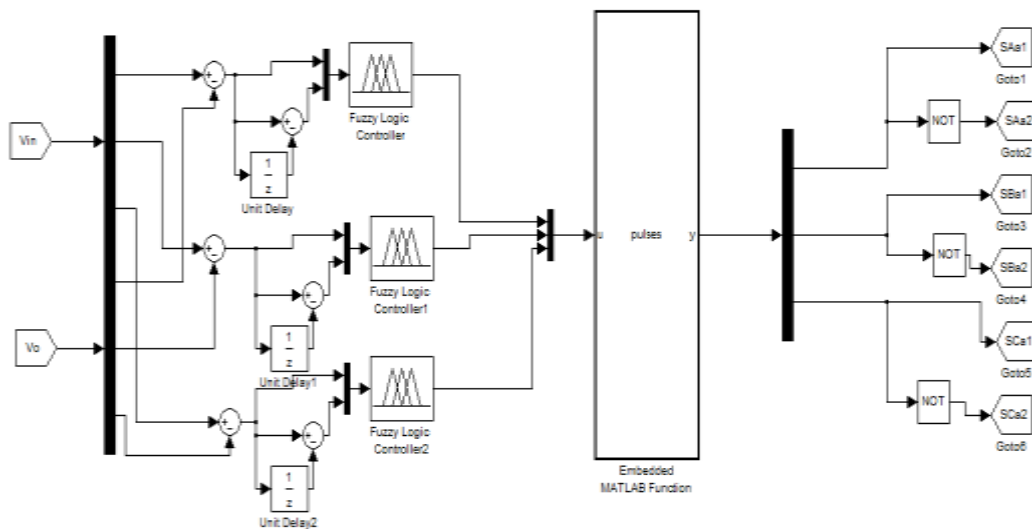

Fig.5: Matlab/simulink blocks for pulses employing FLC based PWM technique

Here the PWM pulses are generated by using Embedded Matlab function developed by coding. The input for the embedded MATLAB function is given from the output of the fuzzy logic.

RESULTS AND DISCUSSION

The proposed control algorithm is tested with an ideal nine-switch three phases to three phase matrix converter feeding a RL load. For this purpose, digital simulations are carried out using Matlab / Simulink software. The simulation parameters are set as; the supply frequency = 50Hz, the input voltage = 480 V, the input current = 27 A, the switching frequency = 2 kHz, resistance =20 Ω , inductance =310 mH.



Fig.6:Input Voltage and Current Waveforms in Steady State Condition

[Hemakesavulu* *et al.*, 6(3): March, 2017]
 ICTM Value: 3.00

Figure 6 shows the input voltage and current waveform given to the matrix converter. The input voltage and current is same for both the modulation techniques.

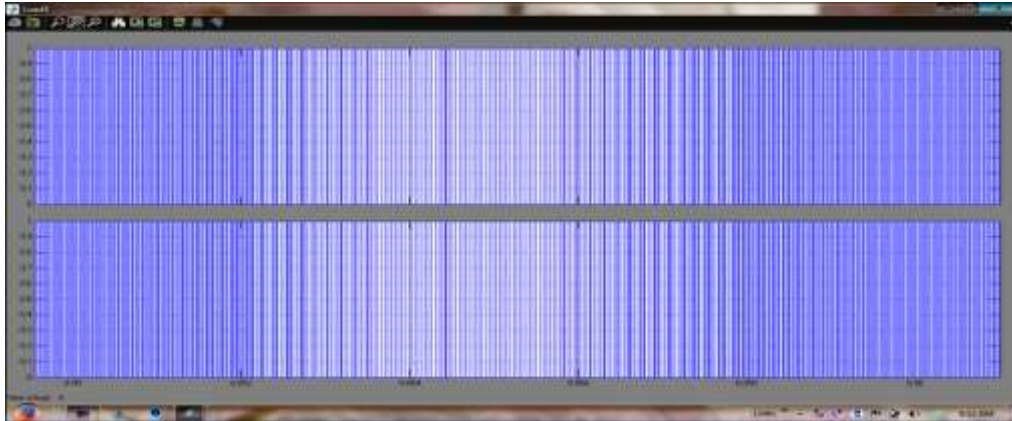

Fig.7.:PWM Pulses for Upper and Lower Switches of Phase A

Figure 7 shows the PWM pulses for upper and lower switches of phase A. The pulses for the lower switches are 180° out of phase with upper switch pulses. Similarly, the pulses can be obtained for phase B and C with a shift of 120° and 240° respectively

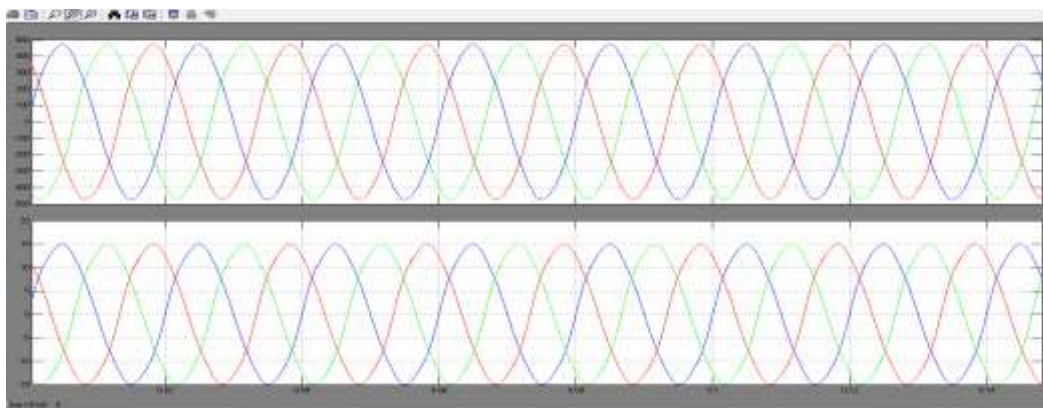

Fig.8: Output Voltage and Current Waveform of Matrix Converter using PWM Technique

Figures 8 and 9 displays steady state conditions of the simulated output voltage, current waveforms and the harmonic profile of the output voltage.

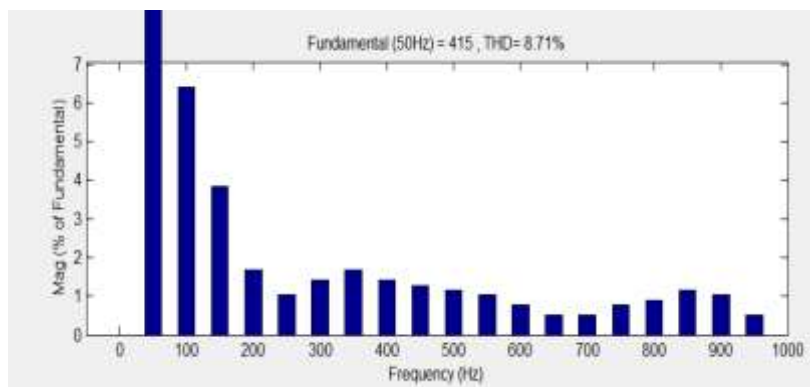

Fig.9: Harmonic Profile of Output Voltage Employing PWM Technique

It can be seen that both output voltage and current are sinusoidal. The fundamental component of the input current waveform is in phase with the input voltage i.e. the input displacement factor is close to unity likewise same in output current waveform is in phase with the output voltage

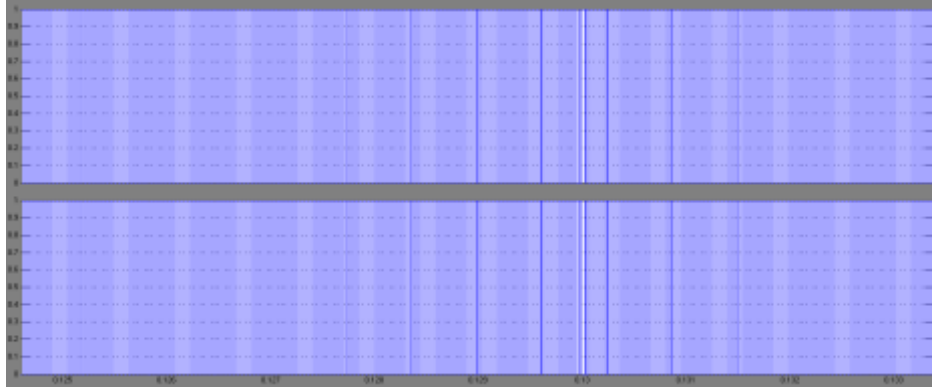

Fig.10: FLC based PWM Pulse for Upper and Lower Switches of Phase A

Figure 10 displays the steady state conditions of the simulated output voltage, current waveforms of matrix converter using PWM technique employing fuzzy logic controller.

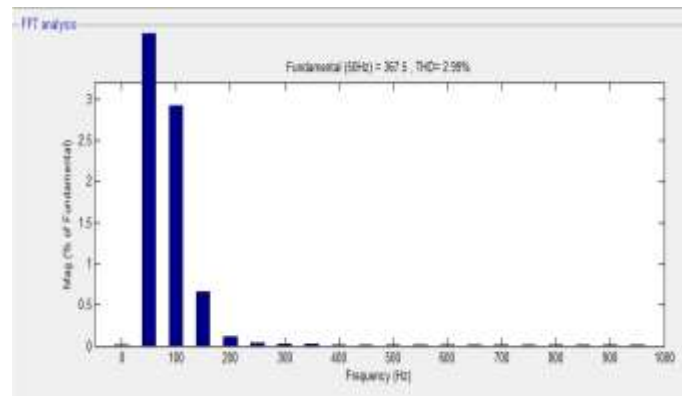

Fig.11: Harmonic Profile of Output Voltage Employing FLC based PWM Technique

Figure 11 displays the harmonic profile of the output voltage of matrix converter using PWM technique employing fuzzy logic controller.

Table 1.Performance Comparison

S.NO	Parameters	PWM	FLC BASED PWM
1	Output voltage (volts)	415	367.5
2	Output current (amperes)	15	13.6
3	THD level (%)	8.71	2.99

The detailed analysis revealed that the output line voltage varies with different schemes of these modulation techniques. The output current in all the three techniques are almost same. PWM has slightly higher value. The simulated values prove that the input and output voltages and currents are sinusoidal. The voltage transfer capability of the matrix converter is approximately 87% for any type of modulation technique. The THD indicates the amount of harmonics present in the system expressed as a percentage. The lower value of THD specifies the lesser harmonics in the output waveform. The THD of the FLC based PWM is lowest under the same switching frequency compared to PWM technique.

CONCLUSION

The proposed Matrix Converter with different modulation techniques was simulated using Matlab/ Simulink model blocks. PWM technique with and without FLC was analyzed in detail and the outputs were presented.

The pulses obtained from various schemes are used to control the output parameters of the matrix converter to convert a given three phase input voltage into a three phase output voltage of a desired frequency and magnitude. Simulation result exhibits that the converter has following performance features: Both the input currents and output voltages are pure sine waveforms with the harmonics around or above the switching frequency. The converter is capable of operating at unity power factor. Four quadrant operations are possible. No bulk DC link capacitors are needed, which means that a large capacity, compact converter system can be designed with better efficiency. It has the same voltage transfer ratio capacity as conventional matrix converter. PWM based FLC has the minimum THD level at the output side and hence the reduced losses on the drives. The control circuit to produce pulses is simplest in PWM technique.

REFERENCES

- [1] Patrick W.Wheeler, Jose Rodriguez, Jhon C. Clare, Lee paper title Empringham and Alejandro Weinstein, "Matrix Converters: A Technology Review", IEEE Transactions on Industrial Electronics, Vol.49, Issue 2, pp. 276-288, April 2002.
- [2] J.Karpagam, Member IEEE, Dr.A.Nirmal Kumar and V.KumarChinnaiyan, "Comparison of Modulation Techniques for Matrix Converter", IACSIT International Journal of Engineering and Technology, Vol.2, No.2, April 2010 ISSN: 1793-8236.
- [3] Apap, M. Clare, J.C. Wheeler and P.W. Bradley, K.J. "Analysis and Comparison of AC-AC Matrix Converter Control Strategies", PESC03, IEEE 34th Annual conference on Power Electronics, Vol. 3, pp. 1287-1292, June 2003.
- [4] Shimada, H. and Takeshita, T. "Matrix Converter Control using Direct AC/AC Conversion Method for Reducing Output Voltage Harmonics" APEC06, IEEE 21st Annual Conference on Applied Power Electronics, Vol. 1, pp. 7-13, March 2006.
- [5] B. K. Bose, "Expert system, fuzzy logic, and neural network applications in power electronics and motion control," in Proc. IEEE PEMC'94, pp. 1303-1323, 1994.
- [6] P. Kirawanich and R. M. O. Connell, "Fuzzy logic control of an active power line conditioner," IEEE Trans. on Power Electron., vol. 19, no. 6, pp. 1574-1585, 2004.
- [7] W. Pedrycz, "Why triangular membership functions," Fuzzy Sets Syst., vol. 64, pp. 21---30, 1994.
- [8] H. Ying, Fuzzy Control and Modeling: Analytical Foundations and Applications, IEEE Press, 2000.